



Models: **UMDN2200/100/3**  
**UADN2200/100/3**



### MODEL NUMBER STRUCTURE

<b>U</b>	Ultraflow
<b>M</b>	'M' indicates Manual, without floatswitch 'A' indicates Automatic, with floatswitch
<b>D</b>	'D' indicates 'Drainage' series
<b>N</b>	'N' indicates New series
<b>2200</b>	Power consumption in 'Watts'
<b>100</b>	Outlet size
<b>3</b>	'3' indicates 415 volt three phase

### SPECIFICATIONS

Power	2.2kW / 3.0HP
Frequency	50Hz
Discharge	100mm / 3 inch female BSP
Weight (Excl cable)	45Kg – UADN2200/100/3 42Kg – UMDN2200/100/3
Solid Passage	20 mm
Phase	3ø
Voltage	415
Full Load Amps	4.8
Maximum Liquid Temperature	0-40° C
Maximum Submersion Depth	30m (100 feet)
Motor type	Dry motor
Motor Speed	2 Pole (2800 rpm)
Motor Insulation	Class B
Motor Protection	IP68
Protector	Auto cut
Motor Bearings	Ball Type
Seal Method	Dual Mechanical seal Upper: Carbon/Ceramic Lower: Silicon/Silicon
Impeller Type	Semi-open
Motor Cover Construction	FC-200 Cast Iron
Motor Casing Construction	304 Stainless Steel
Motor Shaft Construction	403 Stainless Steel
Pump Casing Construction	FC-200 Cast Iron
Impeller Construction	FC-200 Cast Iron
Strainer Construction	304 Stainless Steel
Cable Material	H07RN-F

### PERFORMANCE CURVES

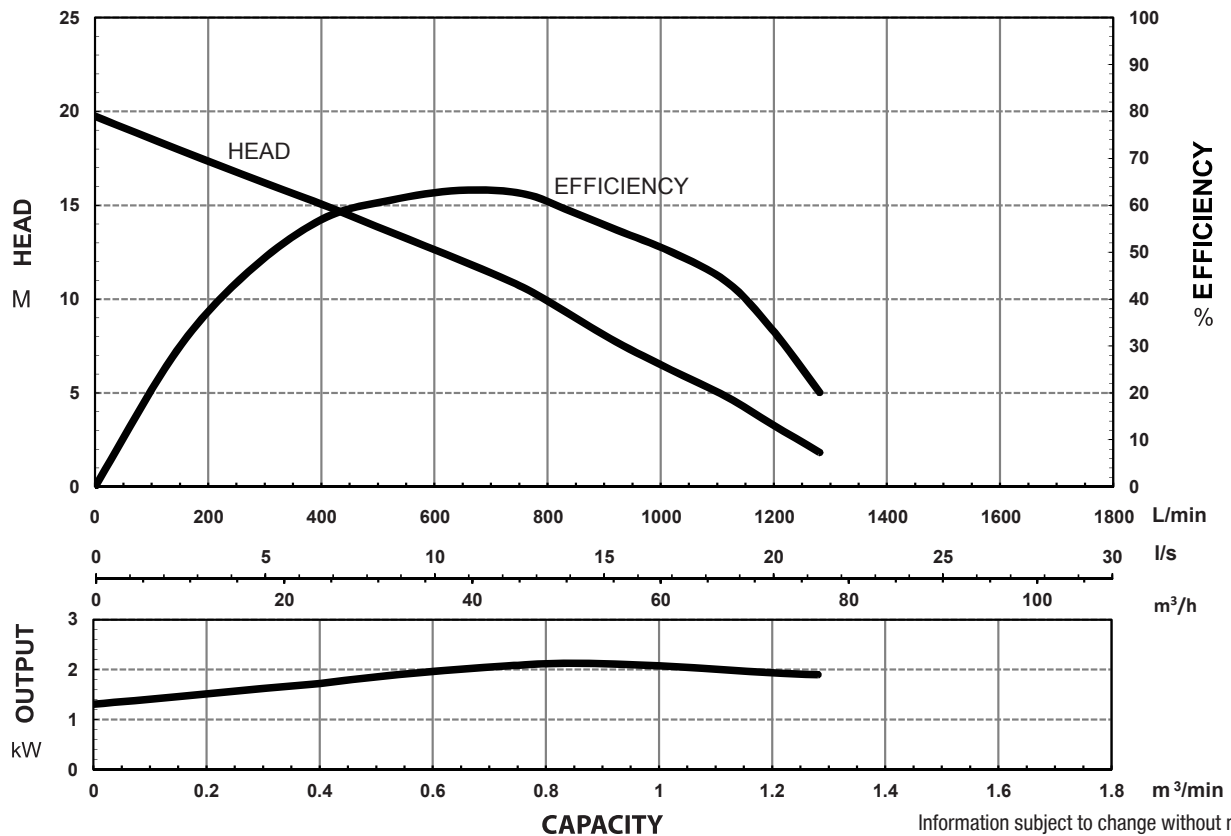

Information subject to change without notice.

Models: **UMDN2200/100/3**  
**UADN2200/100/3**



**SECTIONAL DRAWING & MATERIALS LIST**

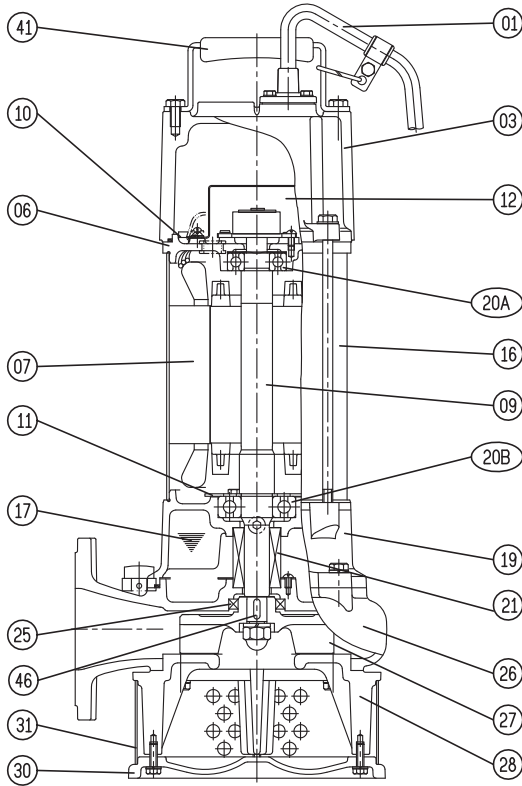

PART NUMBER	DESCRIPTION	MATERIAL
01	Cable	H07RN-F
03	Upper Motor Cap (Part 3 & 6 are one part on UMDZ2200/100/3)	Cast Iron FC-200
06	Upper Bearing Housing	Cast Iron FC-200
07	Motor Stator	
09	Shaft (With Rotor)	(Shaft) Stainless Steel 403
10	Auto Cut Out Overload	
11	Bearing Fixing Plate	
12	Transformer relay (UADZ2200/80/3 only)	
16	Motor Casing	304 Stainless Steel
17	Lubricant	Turbine Oil
19	Lower Bearing Housing	Cast Iron FC-200
20A	Upper Bearing	
20B	Lower Bearing	
21	Mechanical Seal	Upper: Carbon/Ceramic Lower: Silicon/Silicon
25	Oil Seal	Nitrile
26	Pump Casing	Cast Iron FC-200
27	Impeller	Cast Iron FC-200
28	Suction Cover Stand	Cast Iron FC-200
30	Pump Base Plate	Cast Iron FC-200
31	Strainer	304 Stainless Steel
41	Handle	304 Stainless Steel
46	Impeller Key	304 Stainless Steel
47	O'rings	
55	Oil Plug	304 Stainless Steel
FL	Floatswitch	

When ordering spare parts as above, simply add the pump model number to the part number from the list above. For example, a power lead (part '01'), the complete spare part name would be written as '01-UADN2200/100/3'.

**DIMENSIONAL DRAWING**

**ELBOW (FLANGE) SET**

**GUIDE RAIL SYSTEM DIMENSIONS USING GR10080 GUIDE RAIL KIT**

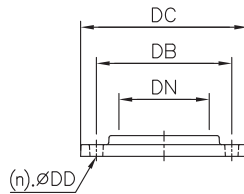
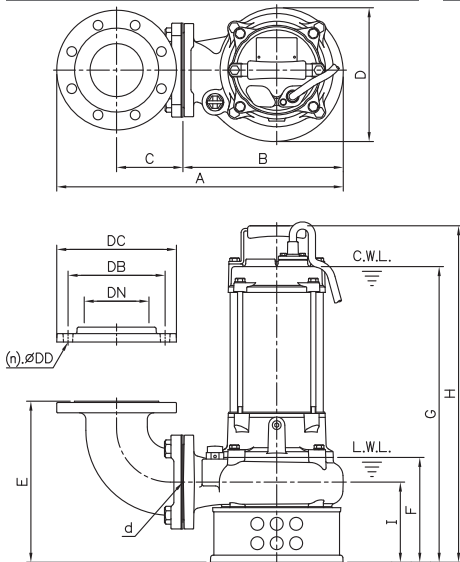

**DIMENSIONS - mm**

DN	DB	DC	DD
80	130	155	12

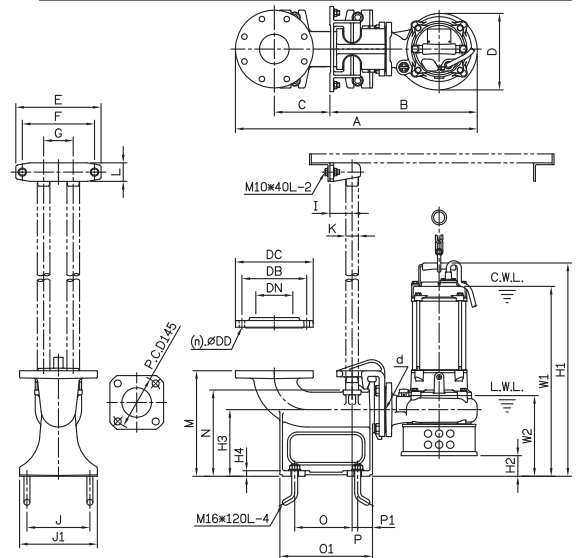

**DIMENSIONS - UADN2200/100/3**

d	A	B	C	D	E	F	G	H	I
80	443	248	103	207	249	162	538	601	124

**DIMENSIONS - UMDN2200/100/3**

d	A	B	C	D	E	F	G	H	I
80	443	248	103	207	249	162	457	520	124

**DIMENSIONS - UADN2200/100/3**

d	A	B	C	D	E	F	G	I	J	J1	K	L	M	N	O	O1	P	P1	W1	W2	H1	H2	H3	H4
80	656	401	150	207	230	195	80	60	170	210	32	50	285	233	155	250	15	40	594	217	657	27	180	15

**DIMENSIONS - UMDN2200/100/3**

d	A	B	C	D	E	F	G	I	J	J1	K	L	M	N	O	O1	P	P1	W1	W2	H1	H2	H3	H4
80	656	401	150	207	230	195	80	60	170	210	32	50	285	233	155	250	15	40	513	217	576	27	180	15

Information subject to change without notice.



T 1300 662 787 | F 1300 662 717

22-24 Somerville Circuit, Emu Plains NSW 2750

E sales@generalpumps.com.au www.generalpumps.com.au