



SPECIFICATIONS

Power	5.5kW / 7.5HP
Frequency	50Hz
Discharge	50mm / 2 inch female BSP
Weight (Excl cable)	53Kg
Phase	3ø
Voltage	415
Full Load Amps	11.4
Maximum Liquid Temperature	0-40° C
Maximum Submersion Depth	10m (30 feet)
Motor type	Dry motor
Motor Speed	2 Pole (2800 rpm)
Motor Insulation	Class F
Motor Protection	IP68
Protector	Auto cut
Motor Bearings	Ball Type
Seal Method	Dual Mechanical seal
	Upper: Carbon/Ceramic
	Lower; Silicon/Silicon
Impeller Type	Semi-open
Motor Cover Construction	FC-200 Cast Iron
Motor Casing Construction	FC-200 Cast Iron
Motor Shaft Construction	403 Stainless Steel
Pump Casing Construction	FC200 Cast Iron
Impeller Construction	FC200 Cast Iron
Grinder	Heat Treated 440 Stainless Steel
Grinder Ring	Heat Treated 440 Stainless Steel
Cable Material	H07RN-F

MODELNUMBER STRUCTURE

U	Ultraflow
M	'M' indicates Manual, without floatswitch
	'A' indicates automatic, with floatswitch
G	'G' indicates 'Grinder' series
N	'N' indicates new series
H	'H' indicates high head model
5500	Power consumption in 'Watts'
50	Outlet size (mm)
3	'3' indicates 415 volt three phase

PERFORMANCE CURVES

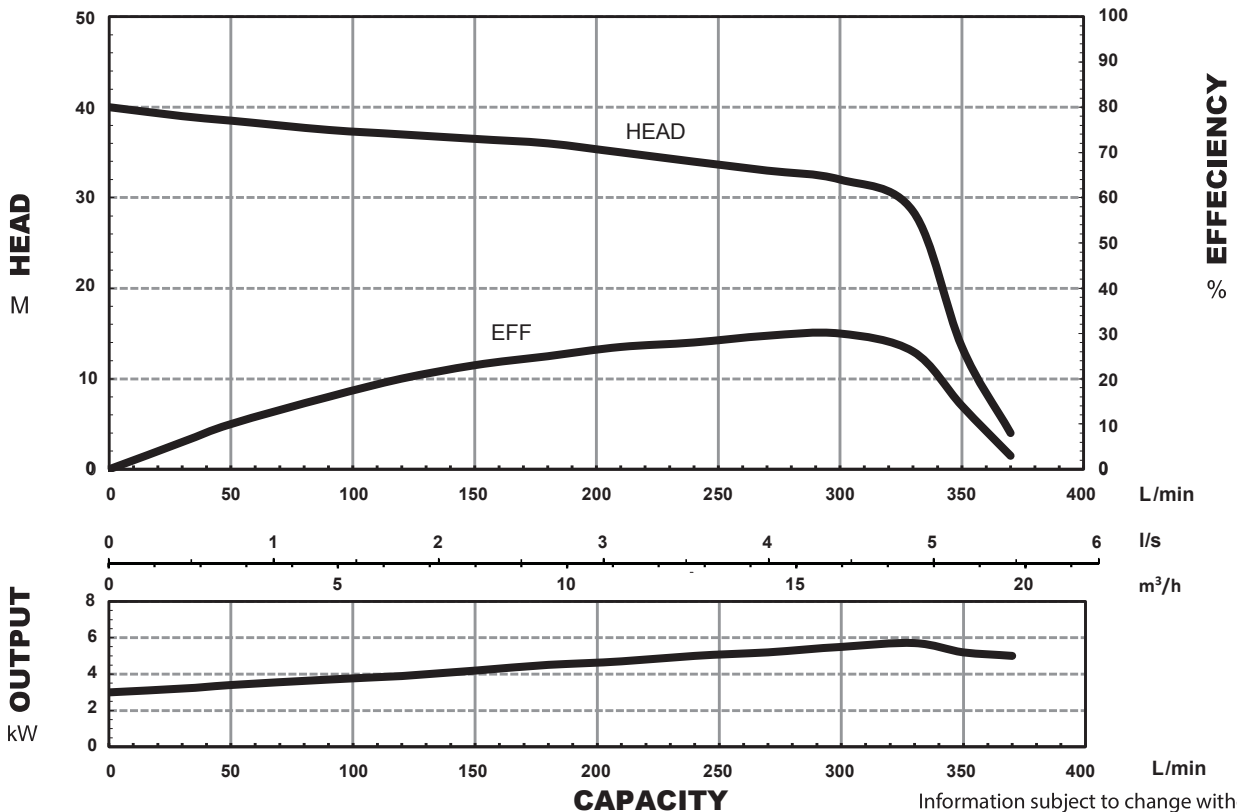

Information subject to change without notice.

SECTIONAL DRAWING & MATERIALS LIST

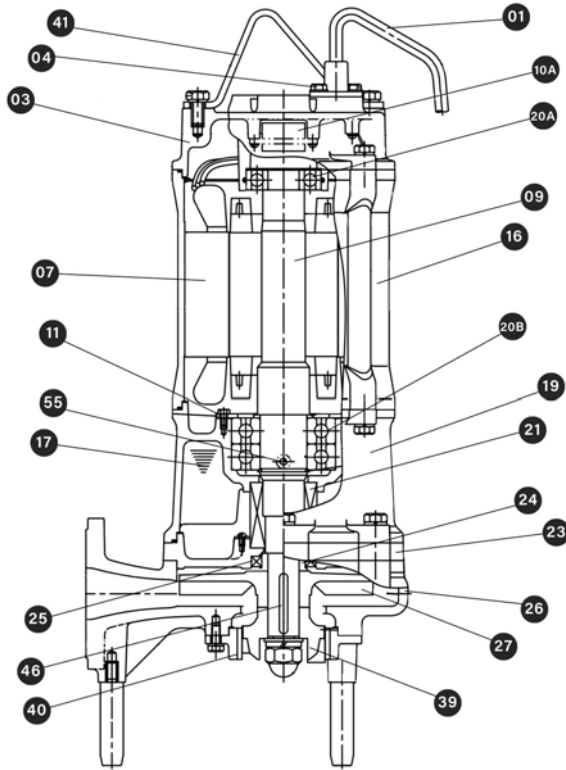

PART NUMBER	DESCRIPTION	MATERIAL
01	Cable	HO7RN-F
03	Upper Motor Cap	Cast Iron FC-200
04	Cable Gland Cover	
07	Motor Stator	
09	Shaft With (With Rotor)	(Shaft) Stainless Steel 403
10 A	Auto Cut Out Overload	
11	Bearing Fixer	
16	Motor Casing	Cast Iron FC-200
17	Lubricant	Turbine Oil
19	Lower Bearing Housing	Cast Iron FC-200
20A & 20B	Upper Bearing & Lower Bearings	
21	Mechanical Seal	Upper: Carbon/Ceramic Lower: Silicon/Silicon
23	Mechanical Seal Housing	Cast Iron FC-200
24	Oil Seal Bush	
25	Oil Seal	Nitrile
26	Pump Casing	Cast Iron FC-200
27	Impeller	Cast Iron FC-200
35	Outlet Elbow	Cast Iron FC-200
36	Outlet Flange	Cast Iron FC-200
39	Grinder	Heat Treated 440 Stainless Steel
40	Grinder ring	Heat Treated 440 Stainless Steel
41	Handle	304 Stainless Steel
46	Impeller Key	304 Stainless Steel
47	O'rings	
55	Oil Plug	304 Stainless Steel

To ordering spare parts as above, it will be necessary to add the model number of the code listed above. For example, a power lead for a UMGNH5500/50/3 would be written as '01-UMGNH5500/50/3'

DIMENSIONAL DRAWING

ELBOW (FLANGE) SET

GUIDE RAIL SYSTEM DIMENSIONS USING GR50HP GUIDE RAIL KIT

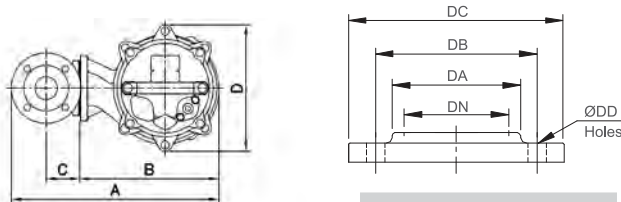

DIMENSIONS - mm				
DN	DA	DB	DC	DD
50	78	120	155	15

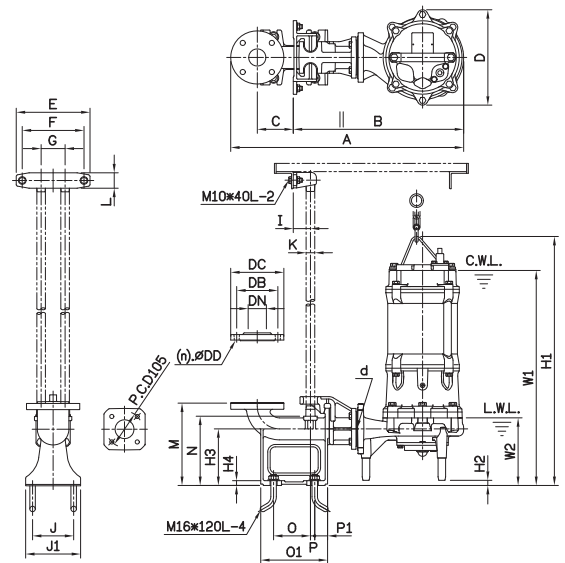
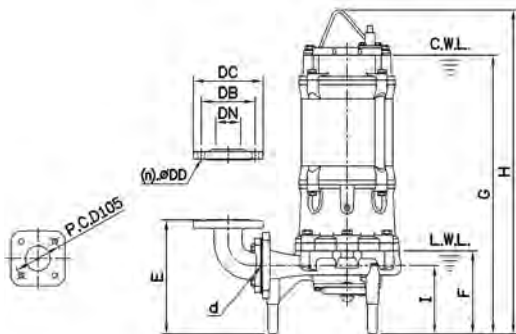

DIMENSIONS - UMGNH5500/50/3								
DN	A	B	C	D	E	F	G	H
50	462	310	75	279	250	182	612	711

DIMENSIONS - UMGNH5500/50/3																			
DN	A	B	C	D	E	F	G	I	J	K	M	N	O	P	W1	W2	H1	H2	H3
50	679	497	105	279	215	180	70	50	120	1"	240	202	108	13	627	197	726	15	165

PUMP LEGS TO BE UNSCREWED FOR GUIDE RAIL APPLICATIONS

Information subject to change without notice