



MODEL NUMBER STRUCTURE

U	Ultraflow
M	'M' indicates Manual, without floatswitch 'A' indicates Automatic, without floatswitch
D	'D' indicates 'Drainage' series
N	'N' indicates series
SS	'SS' indicates Stainless Steel wetted parts
2200	Power consumption in 'Watts'
80	Outlet size
3	'3' indicates 415 volt three phase

SPECIFICATIONS

Power	2.2kW / 3.0HP
Frequency	50Hz
Discharge	80mm / 3 inch female BSP
Weight (Excl cable)	30Kg
Solid Passage	20 mm
Phase	3ø
Voltage	415
Full Load Amps	4.8
Maximum Liquid Temperature	0-40° C
Maximum Submersion Depth	30m (100 feet)
Motor type	Dry motor
Motor Speed	2 Pole (2800 rpm)
Motor Insulation	Class B
Motor Protection	IP68
Protector	Auto cut
Motor Bearings	Ball Type
	Dual Mechanical seal
Seal Method	Upper: Carbon/Ceramic Lower: Silicon/Silicon
Impeller Type	Semi-open
Motor Cover Construction	SCS14 Stainless Steel
Motor Casing Construction	316 Stainless Steel
Motor Shaft Construction	316 Stainless Steel
Pump Casing Construction	SCS14 Stainless Steel
Impeller Construction	SCS14 Stainless Steel
Strainer Construction	304 Stainless Steel
Cable Material	H07RN-F

PERFORMANCE CURVES

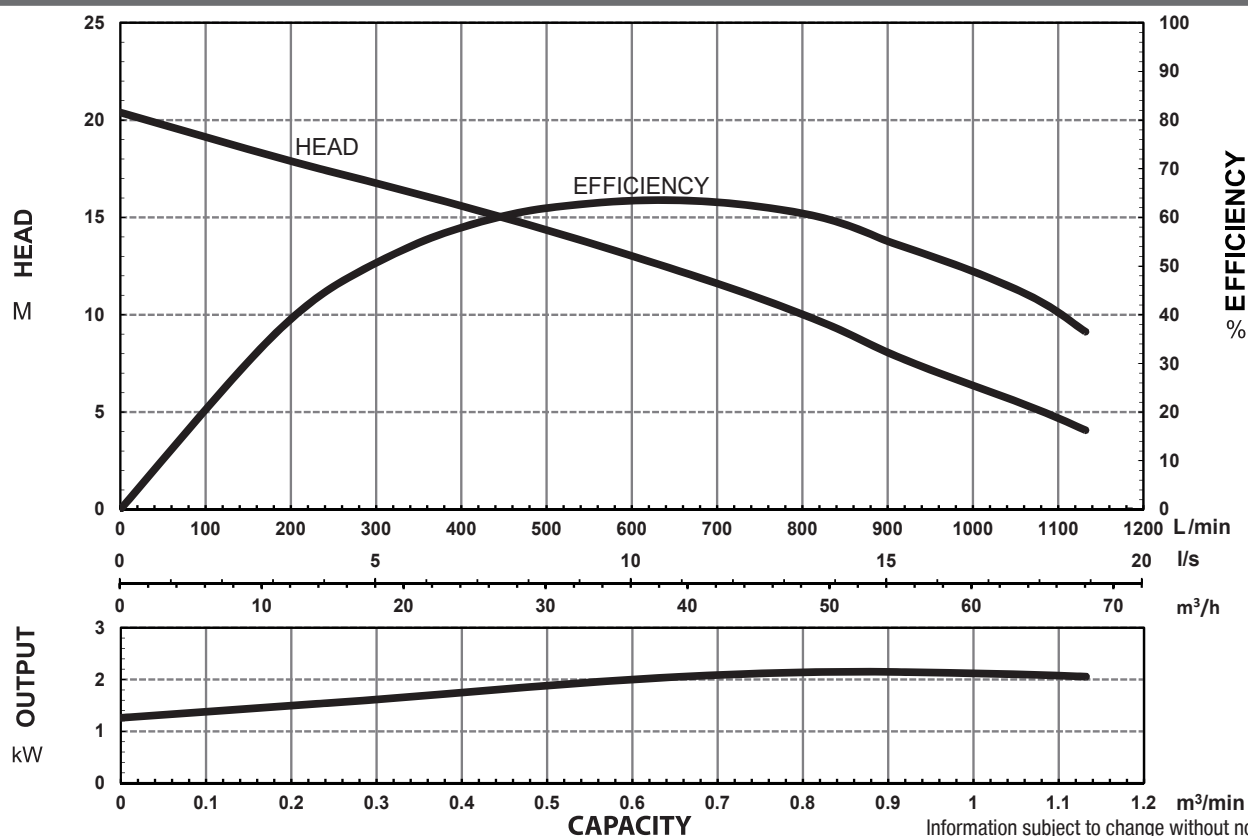

Information subject to change without notice.

SECTIONAL DRAWING & MATERIALS LIST

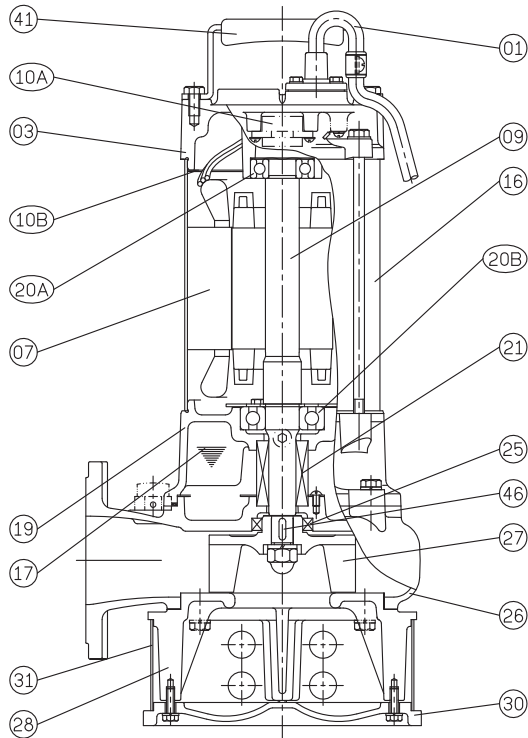

PART NUMBER	DESCRIPTION	MATERIAL
01	Cable	H07RN-F
03	Upper Motor Cap/ Bearing Housing	SCS14 Stainless Steel
07	Motor Stator	
09	Shaft With (With Rotor)	(Shaft) Stainless Steel 316
10 A	Auto Cut Out Overload	
10B	Auto Cut Out Overload Mounting Plate	
16	Motor Casing	316 Stainless Steel
17	Lubricant	Turbine Oil
19	Lower Bearing Housing	SCS14 Stainless Steel
20A & 20B	Upper Bearing & Lower Bearing	
21	Mechanical Seal	Upper: Carbon/Ceramic Lower: Silicon/Silicon
25	Oil Seal	Nitrile
26	Pump Casing	SCS14 Stainless Steel
27	Impeller	SCS14 Stainless Steel
28	Suction Cover	SCS14 Stainless Steel
30	Pump Base Plate	SCS14 Stainless Steel
31	Strainer	316 Stainless Steel
41	Handle	304 Stainless Steel
46	Impeller Key	304 Stainless Steel
47	O'rings	
55	Oil Plug	304 Stainless Steel

When ordering spare parts as above, simply add the pump model number to the part number from the list above. For example, a power lead (part '01'), the complete spare part name would be written as '01-UMDNSS2200/80/3'.

DIMENSIONAL DRAWING

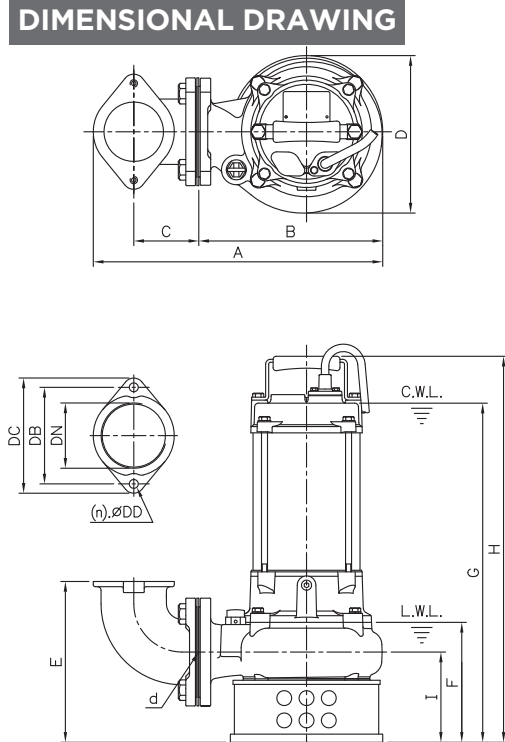

DIMENSIONS - mm UMDNSS2200/80/3									
d	A	B	C	D	E	F	G	H	I
80	390	248	88	212	217	162	457	520	122

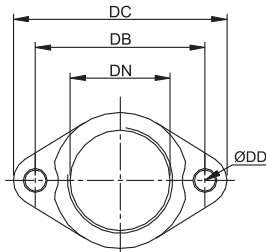

DIMENSIONS - mm			
DN	DB	DC	DD
80	130	155	12

**GUIDE RAIL SYSTEM DIMENSIONS
USING GRSS80B GUIDE RAIL KIT**

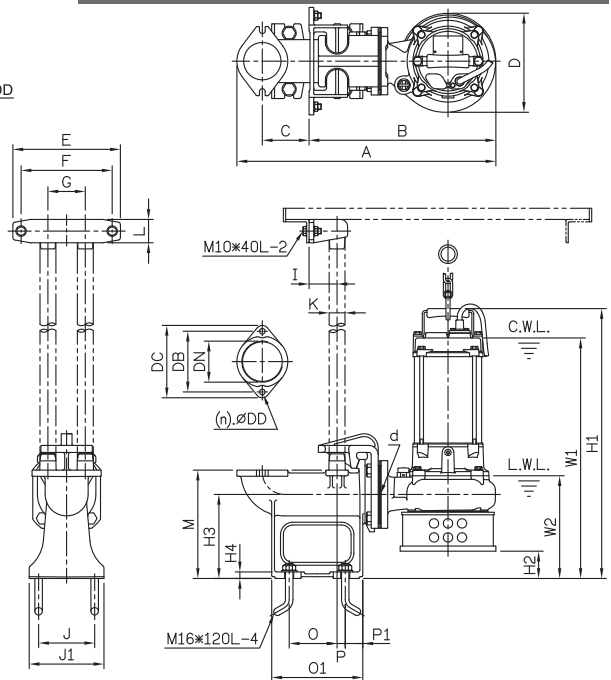

DIMENSIONS - UMDNSS2200/80/3																							
d	A	B	C	D	E	F	G	I	J	J1	K	L	M	O	O1	P	P1	W1	W2	H1	H2	H3	H4
80	555	400	100	212	230	195	80	60	120	160	32	50	232	103	195	18	38	515	220	578	59	180	14

Information subject to change without notice.