



Models: **UMVNSS750/50/1**
UAVNSS750/50/1
UMVNSS750/50/3
UAVNSS750/50/3



MODEL NUMBER STRUCTURE

U	Ultraflow
M	'M' indicates Manual, without floatswitch 'A' indicates Automatic, without floatswitch
V	'V' indicates 'Vortex' series
N	'N' indicates 'Cutter' series
SS	'SS' indicates Stainless Steel wetted parts
750	Power consumption in 'Watts'
50	Outlet size
1	'1' indicates 240 volt single phase '3' indicates 415 volt three phase

SPECIFICATIONS

Power	0.75kW / 1.0HP	
Frequency	50Hz	
Discharge	50mm / 2 inch female BSP	
Weight (Excl cable)	16Kg – Single Phase Model 15Kg – Three Phase Models	
Solid Passage	35 mm	
Phase	1Ø	3Ø
Voltage	240	415
Full Load Amps	5.0	1.8
Maximum Liquid Temperature	0-40° C	
Maximum Submersion Depth	30m (100 feet)	
Motor type	Dry motor	
Motor Speed	2 Pole (2800 rpm)	
Motor Insulation	Class B	
Motor Protection	IP68	
Protector	Auto cut	
Motor Bearings	Ball Type	
Seal Method	Dual Mechanical seal	
	Upper: Carbon/Ceramic Lower: Silicon/Silicon	
Impeller Type	Vortex	
Motor Cover Construction	SCS14 Stainless Steel	
Motor Casing Construction	316 Stainless Steel	
Motor Shaft Construction	316 Stainless Steel	
Pump Casing Construction	SCS14 Stainless Steel	
Impeller Construction	SCS14 Stainless Steel	
Cable Material	H07RN-F	

PERFORMANCE CURVES

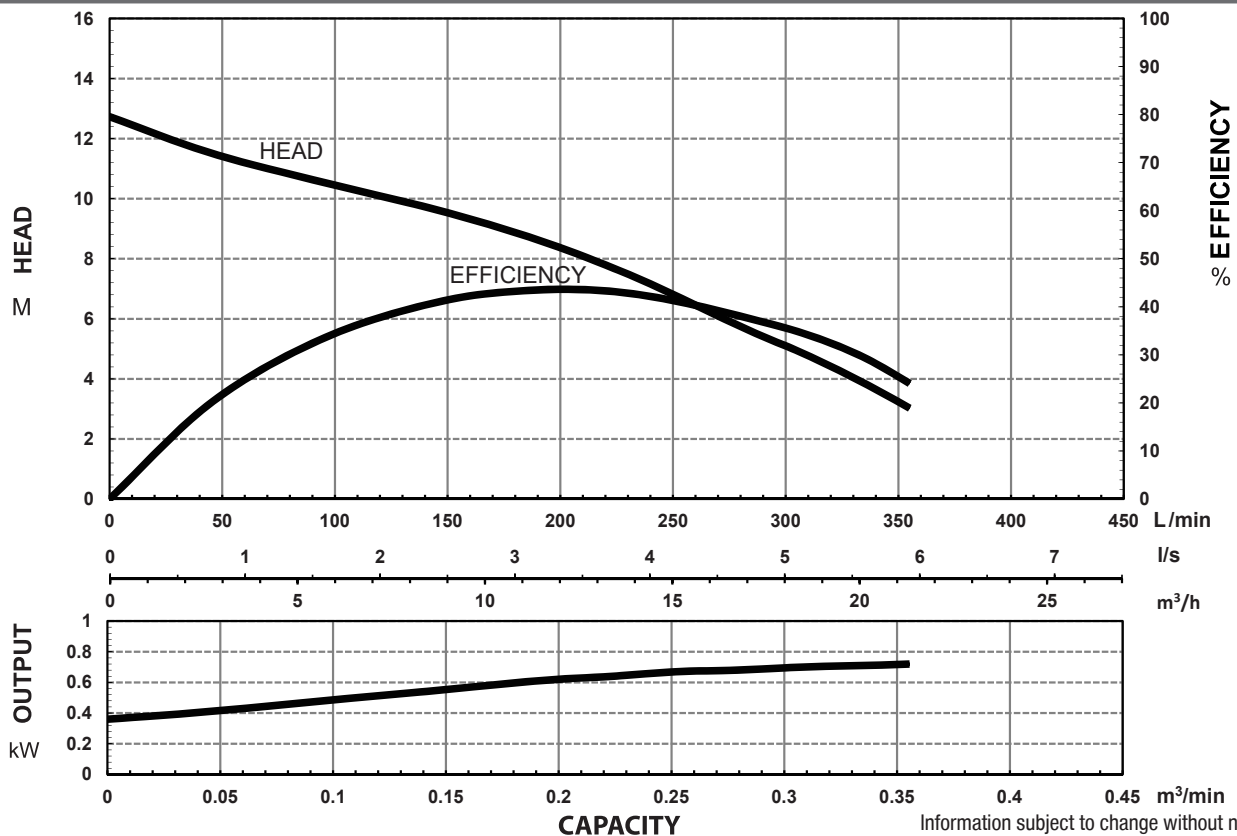

Information subject to change without notice.

SECTIONAL DRAWING & MATERIALS LIST

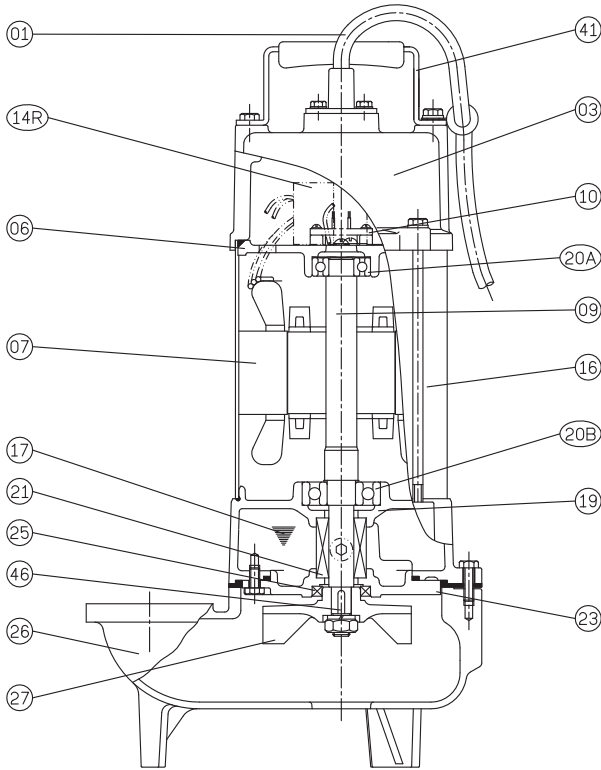

PART NUMBER	DESCRIPTION	MATERIAL
01	Cable	H07RN-F
03	Upper Motor Cap	SCS14 Stainless Steel
06	Upper Bearing Housing	Cast Iron FC-200
07	Motor Stator	
09	Shaft With (With Rotor)	(Shaft) Stainless Steel 316
10	Auto Cut Out Overload	
14R	Capacitor (240 volt models)	
	Transformer relay for UAVNSS750/50/3)	
16	Motor Casing	316 Stainless Steel
17	Lubricant	Turbine Oil
19	Lower Bearing Housing	SCS14 Stainless Steel
20A & 20B	Upper Bearing & Lower Bearing	
21	Mechanical Seal	Upper: Carbon/Ceramic Lower: Silicon/Silicon
23	Mechanical Seal Housing	SCS14 Stainless Steel
25	Oil Seal	Nitrile
26	Pump Casing	SCS14 Stainless Steel
27	Impeller	SCS14 Stainless Steel
36	Outlet Flange	SCS14 Stainless Steel
41	Handle	304 Stainless Steel
46	Impeller Key	304 Stainless Steel
47	O'rings	
55	Oil Plug	304 Stainless Steel
FL	Floatswitch	

When ordering spare parts as above, simply add the pump model number to the part number from the list above. For example, a power lead (part '01'), the complete spare part name would be written as '01-UAVNSS400/50/1'.

DIMENSIONAL DRAWING

ELBOW (FLANGE) SET

GUIDE RAIL SYSTEM DIMENSIONS USING GRSS50B GUIDE RAIL KIT

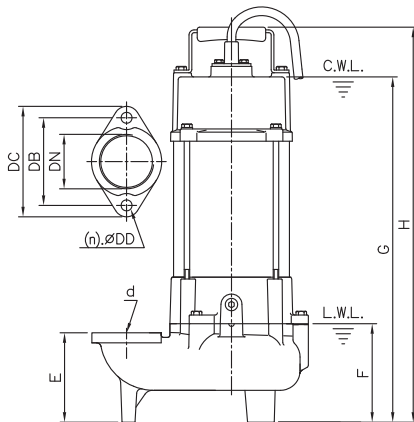
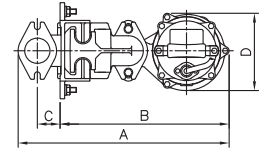
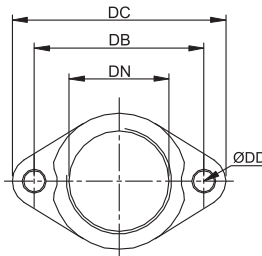
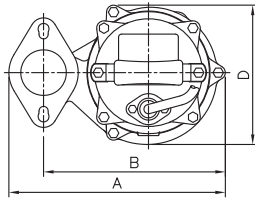

DIMENSIONS - mm

DN	DB	DC	DD
50	96	121	12

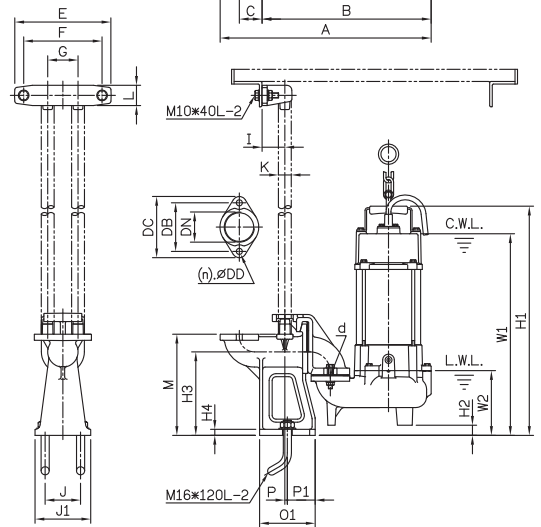

DIMENSIONS - mm

d	A	B	D	E	F	G	H
50	237	199	153	98	108	379	433

DIMENSIONS - mm

d	A	B	C	D	E	F	G	I	J	J1	K	L	M	O1	P	P1	W1	W2	H1	H2	H3	H4
50	417	334	45	153	190	155	60	45	70	110	19	40	200	110	5	55	399	128	453	20	165	12

Information subject to change without notice.