



SPECIFICATIONS

Power	1.5kW / 2.0HP
Frequency	50Hz
Discharge	80mm / 3 inch female BSP
Weight (Excl cable)	29KG
Solid Passage	35 mm
Phase	3ø
Voltage	415
Full Load Amps	3.4
Maximum Liquid Temperature	0-40° C
Maximum Submersion Depth	10m (33 feet)
Motor type	Dry motor
Motor Speed	2 Pole (2800 rpm)
Motor Insulation	Class B
Motor Protection	IP68
Protector	Auto cut
Motor Bearings	Ball Type
	Dual Mechanical seal
Seal Method	Upper: Carbon/Ceramic Lower: Silicon/Silicon
Impeller Type	Semi-open
Motor Cover Construction	SCS14 Stainless Steel
Motor Casing Construction	316 Stainless Steel
Motor Shaft Construction	316 Stainless Steel
Pump Casing Construction	SCS14 Stainless Steel
Impeller Construction	SCS14 Stainless Steel
Cable Material	H07RN-F

MODEL NUMBER STRUCTURE

U	Ultraflow
M	'M' indicates Manual, without floatswitch
C	'C' indicates 'Channel Impeller' series
N	'N' indicates series
SS	'SS' indicates 'Stainless Steel'
1500	Power consumption in 'Watts'
80	Outlet size
3	'3' indicates 415 volt three phase

PERFORMANCE CURVES

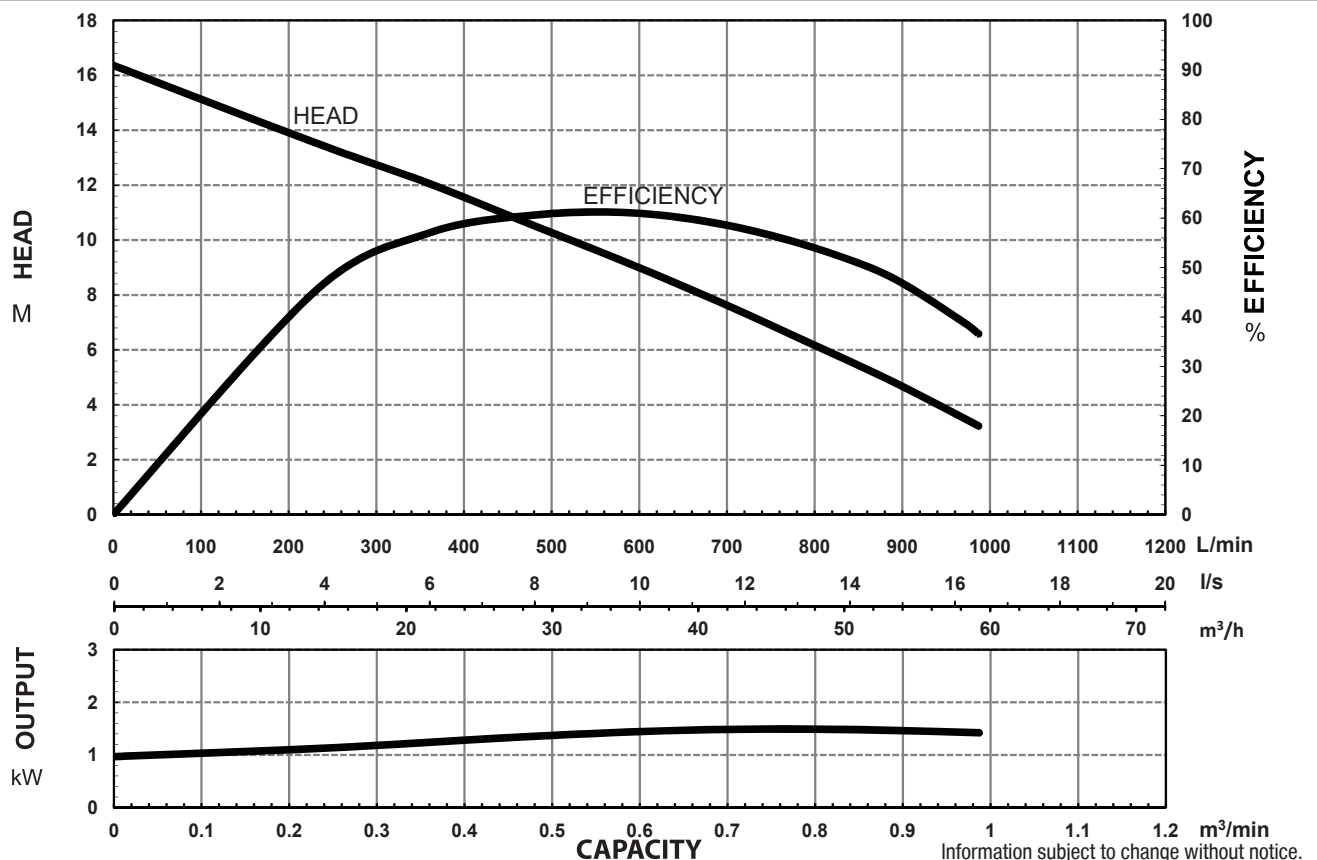

Information subject to change without notice.

Models: UMCNSS1500/80/3



SECTIONAL DRAWING & MATERIALS LIST

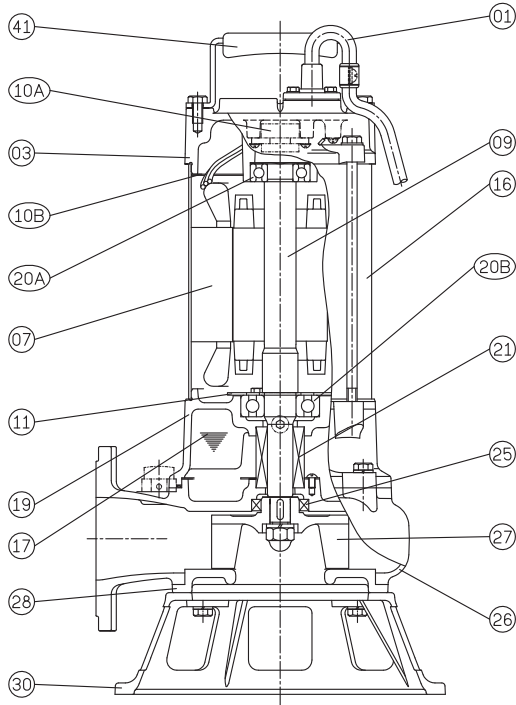

PART NUMBER	DESCRIPTION	MATERIAL
01	Sensor Cable	H07RN-F
03	Upper Motor Cap/ Bearing Housing	SCS14 Stainless Steel
07	Motor Stator	
09	Shaft (With Rotor)	316 Stainless Steel
10A	Auto Cut Out Overload	
10B	Auto Cut Out Overload Mounting Plate	
16	Motor Casing	316 Stainless Steel
17	Lubricant	Turbine Oil
19	Lower Bearing Housing	SCS14 Stainless Steel
20A & 20B	Upper Bearing & Lower Bearing	
21	Mechanical Seal	Upper: Carbon/Ceramic Lower: Silicon/Silicon
25	Oil Seal	Nitrile
26	Pump Casing	SCS14 Stainless Steel
27	Impeller	SCS14 Stainless Steel
28	Suction Cover	SCS14 Stainless Steel
30	Pump Base Plate	SCS14 Stainless Steel
41	Handle	304 Stainless Steel
46	Impeller Key	304 Stainless Steel
47	O'rings	
55	Oil Plug	SCS14 Stainless Steel

When ordering spare parts as above, simply add the pump model number to the part number from the list above. For example, a power lead (part '01'), the complete spare part name would be written as '01-UMCNSS1500/80/3'.

DIMENSIONAL DRAWING

ELBOW (FLANGE) SET

GUIDE RAIL SYSTEM DIMENSIONS USING GRSS80B GUIDE RAIL KIT

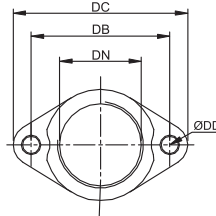
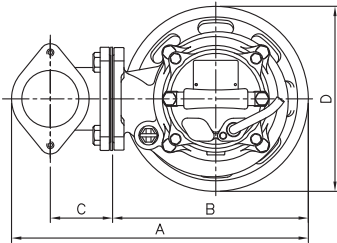

DIMENSIONS - mm

DN	DB	DC	DD
80	130	155	12

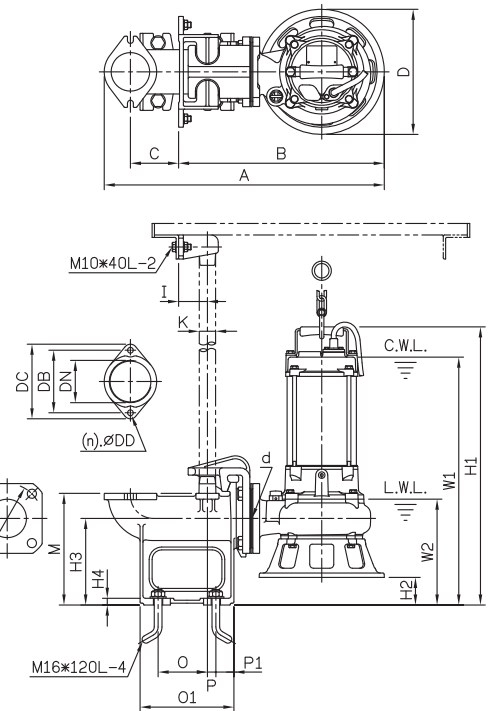
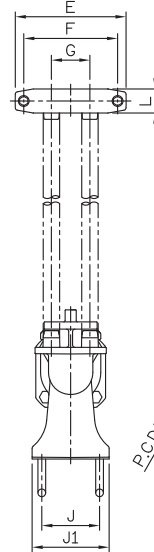
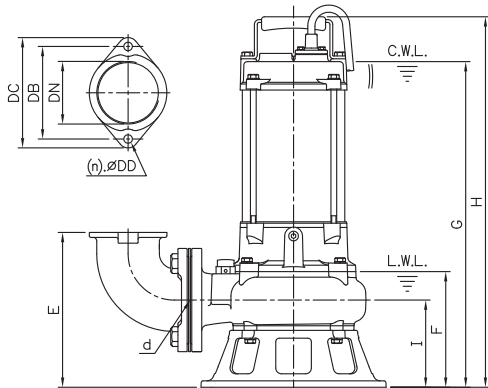

**DIMENSIONS - mm
UMCNSS1500/80/3**

d	A	B	C	D	E	F	G	H	I
80	417	275	88	260	218	163	458	521	123

DIMENSIONS - UMCNSS1500/80/3

d	A	B	C	D	E	F	G	I	J	J1	K	L	M	O	O1	P	P1	W1	W2	H1	H2	H3	H4
80	582	428	100	260	230	195	80	60	120	160	32	50	232	103	195	18	38	515	220	578	58	180	14

Information subject to change without notice.



T 1300 662 787 | F 1300 662 717
 22-24 Somerville Circuit, Emu Plains NSW 2750
 E sales@generalpumps.com.au www.generalpumps.com.au