



SPECIFICATIONS

Power	5.5kW / 7HP
Frequency	50Hz
Discharge	150mm / 6 inch female BSP
Weight (Excl cable)	85Kg
Solid Passage	10 mm
Phase	3ø
Voltage	415
Full Load Amps	11.0
Maximum Liquid Temperature	0-40° C
Motor type	Dry motor
Motor Speed	2 Pole (2800 rpm)
Motor Insulation	Class F
Motor Protection	IP68
Protector	Auto cut
Motor Bearings	Ball Type
	Dual Mechanical seal
Seal Method	Upper: Carbon/Ceramic Lower: Silicon/Silicon
Impeller Type	Semi Open
Motor Cover Construction	FC-200 Cast Iron
Motor Casing Construction	FC-200 Cast Iron
Motor Shaft Construction	304 Stainless Steel
Pump Casing Construction	FC-200 Cast Iron
Impeller Construction	Hi-Chromium
Strainer Construction	304 Stainless Steel
Agitator Construction	FCD700 Hardened Cast Iron
Cable Material	H07RN-F

MODEL NUMBER STRUCTURE

U	Ultraflow
M	'M' indicates Manual, without floatswitch
HDD	'HDD' indicates 'Heavy Duty Drainage' series
A	'A' indicates fitted with agitator
N	'N' indicates series
5500	Power consumption in 'Watts'
150	Outlet size
3	'3' indicates 415 volt three phase

PERFORMANCE CURVES

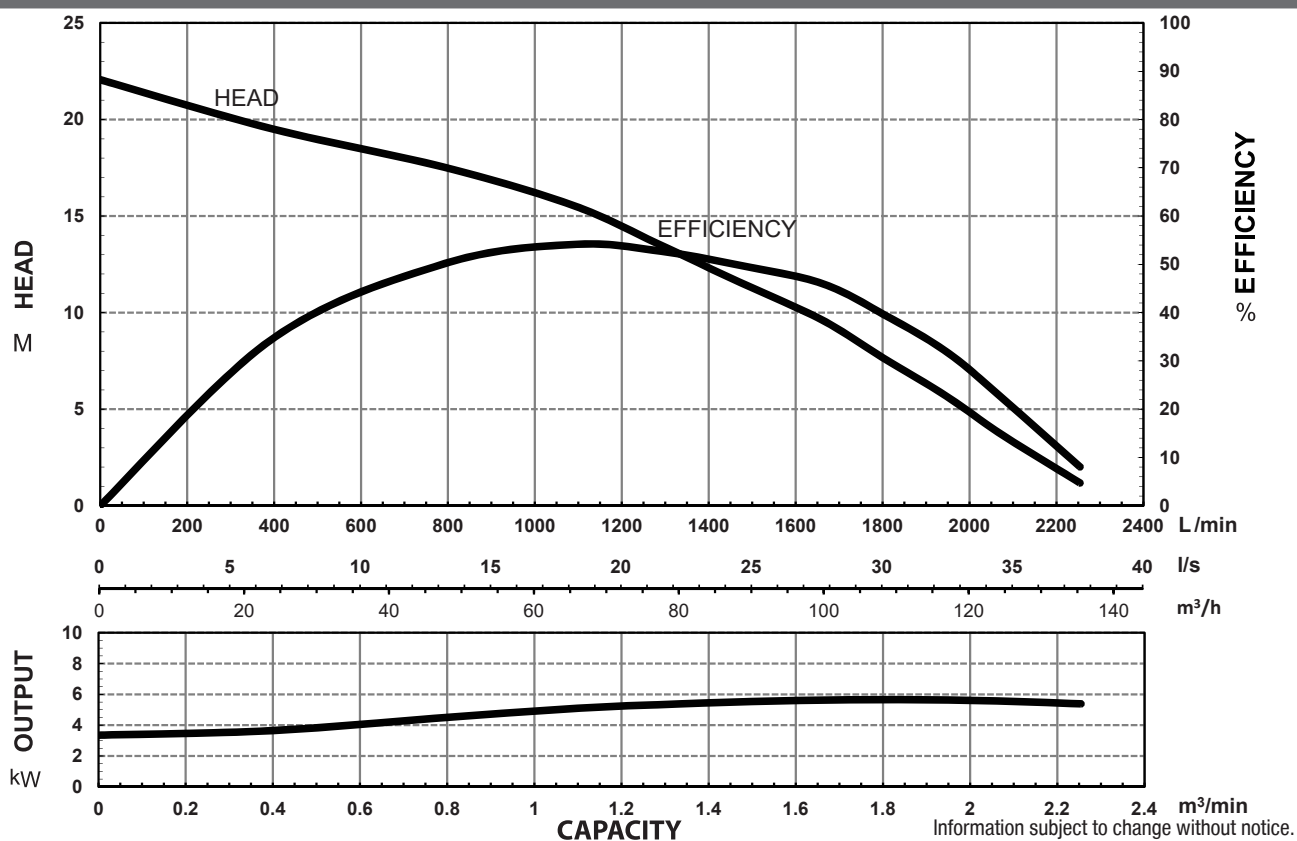

Models: **UMHDDAN5500/150/3**

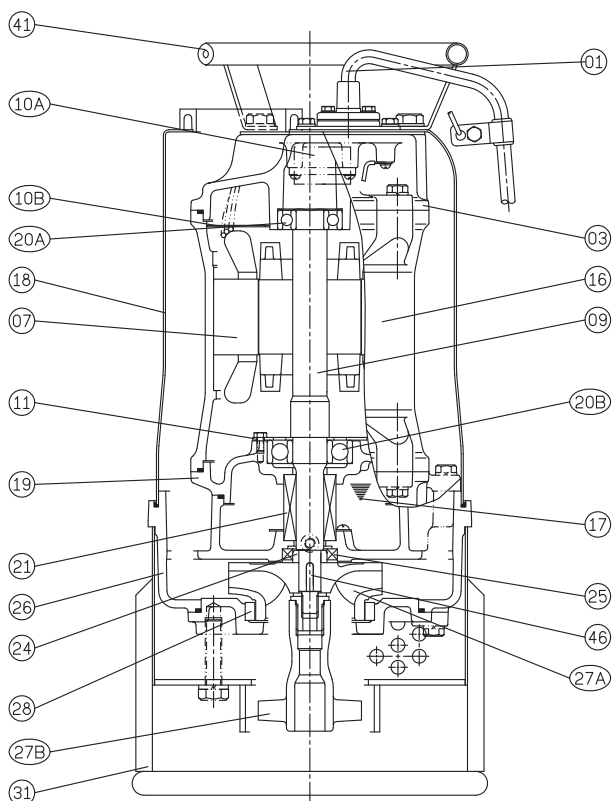

SECTIONAL DRAWING & MATERIALS LIST



PART NUMBER	DESCRIPTION	MATERIAL
01	Cable	H07RN-F
03	Upper Motor Cap	FC200 Cast Iron
07	Motor Stator	
09	Shaft With (With Rotor)	(Shaft) Stainless Steel 304
10A	Auto Cut Out Overload	
10B	Auto Cut Out Mounting Plate	
11	Bearing Fixing Plate	
16	Motor Casing	FC200 Cast Iron
17	Lubricant	Turbine Oil
18	Outer Cover	304 Stainless Steel
19	Lower Bearing Housing	FC200 Cast Iron
20A & 20B	Upper Bearing & Lower Bearing	
21	Mechanical Seal	Upper: Carbon/Ceramic Lower: Silicon/Silicon
24	Oil Seal Bush	SUS403 Stainless Steel
25	Oil Seal	Nitrile
26	Pump Casing	FC200 Cast Iron
27A	Impeller	Hi-Chromium
27B	Agitator	FCD700 Hardened Cast Iron
28	Suction Cover (with wear ring)	Cast Iron FC-200 (Hi-Chrome)
29	Wear Plate	Hi-Chromium
30	Base Foot	Cast Iron FC-200
31	Strainer	304 Stainless Steel
41	Handle	304 Stainless Steel
46	Impeller Key	304 Stainless Steel
47	O'rings	

When ordering spare parts as above, simply add the pump model number to the part number from the list above. For example, a power lead (part '01'), the complete spare part name would be written as '01-UMHDDAN5500/150/3'.

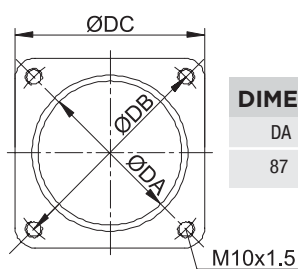
PUMP OUTLET DIMENSIONS



DIMENSIONS - mm

DA	DB	DC
87	127	112

LKF6-240*127PT OUTLET FLANGE KIT DIMENSIONS

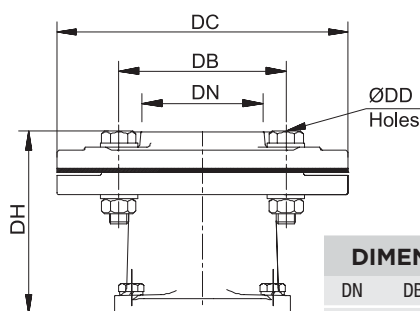

DIMENSIONS - mm

DN	DB	DC	DD	DH
150	240	280	23	160

DIMENSIONAL DRAWING

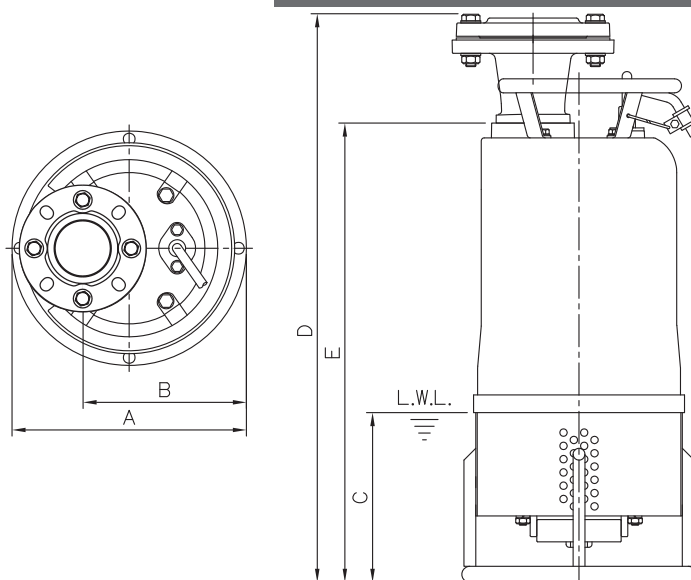

DIMENSIONS - mm UMHDDAN5500/150/3

A	B	C	D	E
361	221	200	783	623

Information subject to change without notice.