



SPECIFICATIONS

Power	11kW / 15HP
Frequency	50Hz
Discharge	100mm / 4 inch female BSP
Weight (Excl cable)	98Kg
Solid Passage	30 mm
Phase	3ø
Voltage	415
Full Load Amps	21.6
Maximum Liquid Temperature	0-40° C
Maximum Submersion Depth	30m (100 feet)
Motor type	Dry motor
Motor Speed	2 Pole (2800 rpm)
Motor Insulation	Class F
Motor Protection	IP68
Protector	Auto cut
Motor Bearings	Ball Type
Seal Method	Dual Mechanical seal
	Upper: Carbon/Ceramic Lower: Silicon/Silicon
Impeller Type	Semi Open
Motor Cover Construction	FC-200 Cast Iron
Motor Casing Construction	FC-200 Cast Iron
Motor Shaft Construction	420J2 Stainless Steel
Pump Casing Construction	FC-200 Cast Iron
Impeller Construction	FC-200 Cast Iron
Cable Material	H07RN-F

MODEL NUMBER STRUCTURE

U	Ultraflow
M	'M' indicates Manual, without floats switch
C	'C' indicates 'Cutter' series
Z	'Z' indicates new series
11000	Power consumption in 'Watts'
100	Outlet size
3	'3' indicates 415 volt three phase

PERFORMANCE CURVES

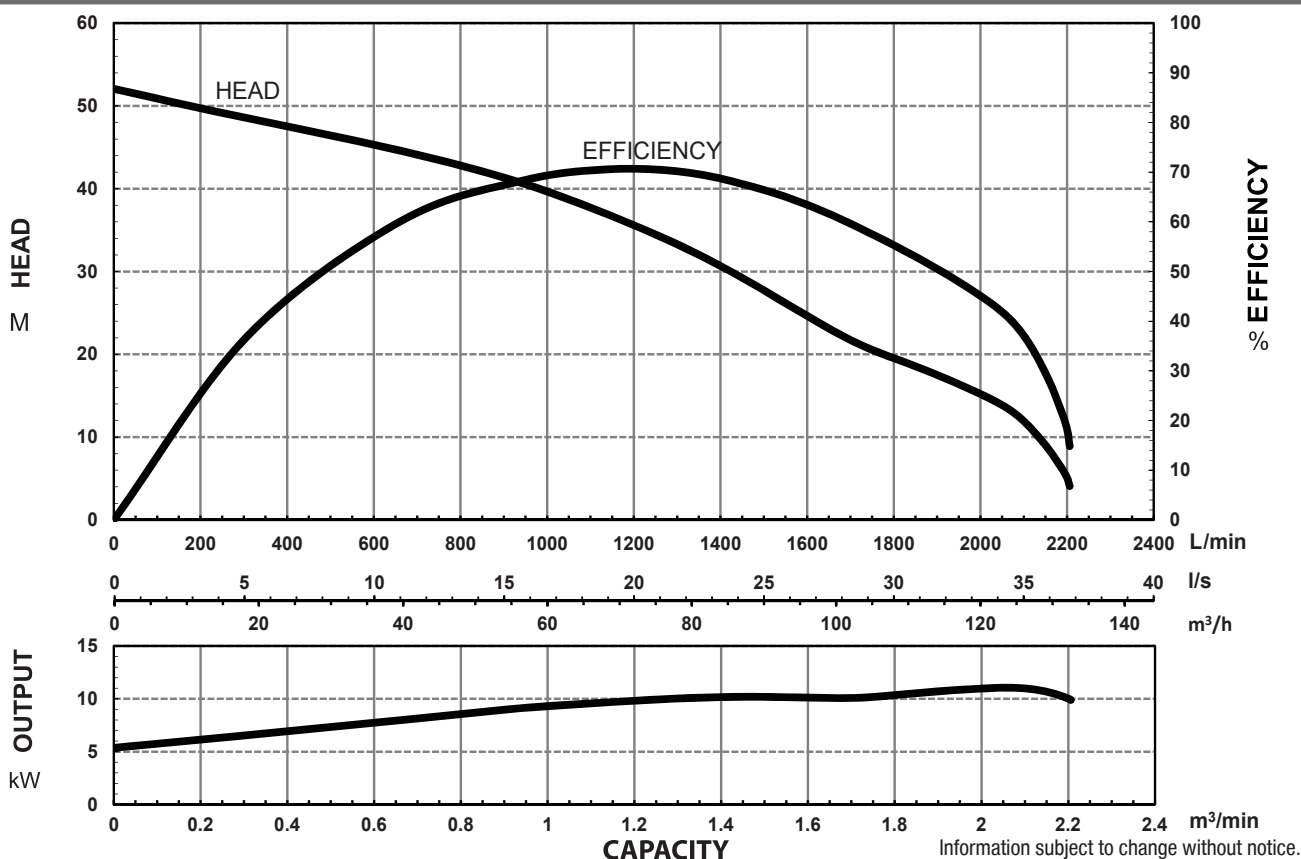

Information subject to change without notice.

Models: **UMCZ11000/100/3**



SECTIONAL DRAWING & MATERIALS LIST

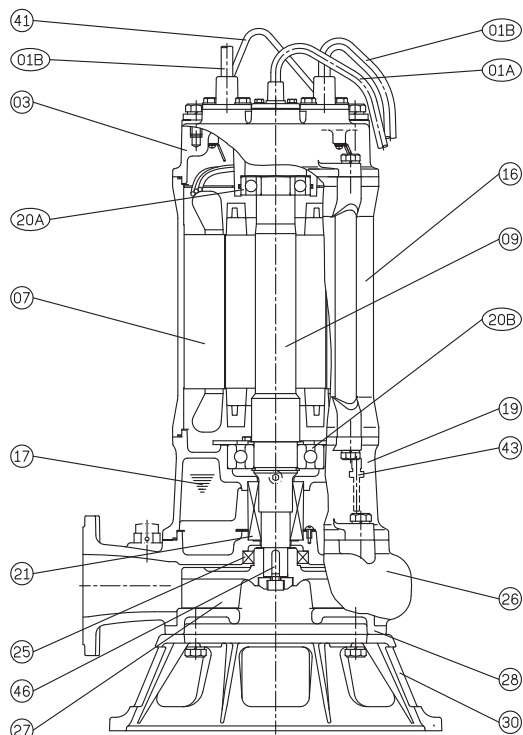

PART NUMBER	DESCRIPTION	MATERIAL
01A	Sensor Cable	H07RN-F
01B	Power Cables	H07RN-F
03	Upper Motor Cap/ Bearing Housing	Cast Iron FC-200
07	Motor Stator	
09	Shaft With (With Rotor)	(Shaft) Stainless Steel 420J2
16	Motor Casing	
17	Lubricant	Turbine Oil
19	Lower Bearing Housing	Cast Iron FC-200
20A & 20B	Upper Bearing & Lower Bearing	
21	Mechanical Seal	Upper: Carbon/Ceramic Lower: Silicon/Silicon
25	Oil Seal	Nitrile
26	Pump Casing	Cast Iron FC-200
27	Impeller	Cast Iron FC-200
28	Casing Cover	Cast Iron FC-200
30	Pump Base Plate	Cast Iron FC-200
41	Handle	304 Stainless Steel
43	Moisture Sensor	
46	Impeller Key	304 Stainless Steel
47	O'rings	
55	Oil Plug	304 Stainless Steel

When ordering spare parts as above, simply add the pump model number to the part number from the list above. For example, a power lead (part '01'), the complete spare part name would be written as '01-UMCZ11000/100/3'.

DIMENSIONAL DRAWING

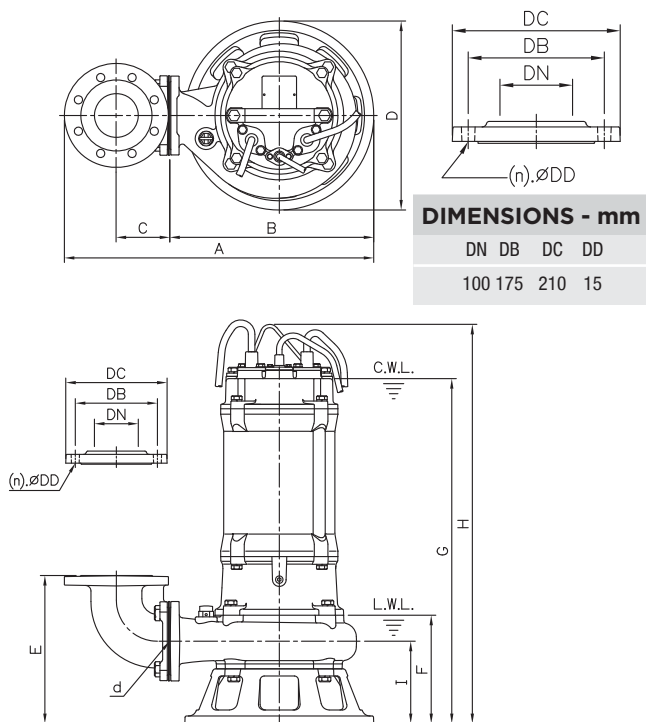

DIMENSIONS - mm

DN	DB	DC	DD
100	175	210	15

GUIDE RAIL SYSTEM DIMENSIONS USING GR10080HP GUIDE RAIL KIT

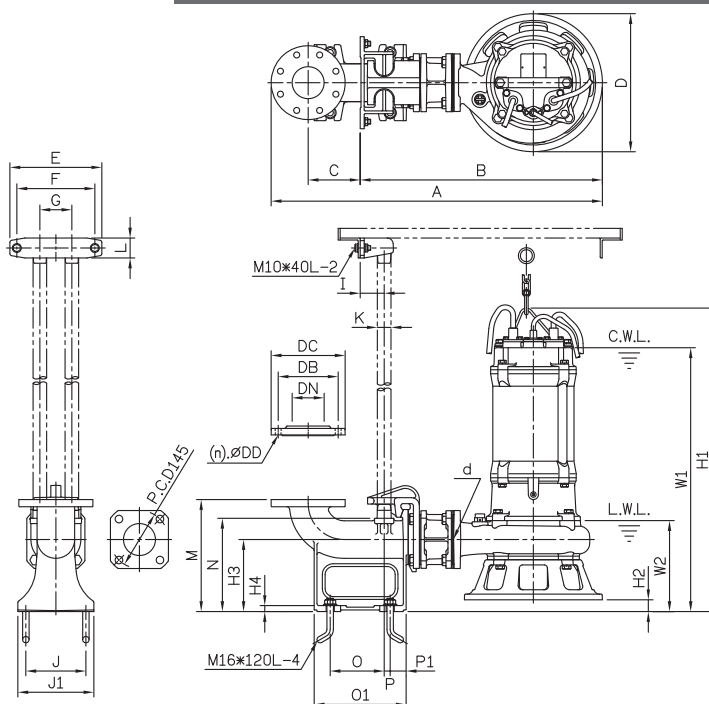

UMDZ11000/100/3

d	A	B	C	D	E	F	G	H	i
80	565	373	113	345	282	198	630	729	151

DIMENSIONS - UMDZ11000/100/3

d	A	B	C	D	E	F	G	I	J	J1	K	L	M	N	O	O1	P	P1	W1	W2	H1	H2	H3	H4
80	860	606	150	345	230	195	80	60	170	210	32	50	285	233	155	250	15	40	660	228	759	30	180	15

Information subject to change without notice.



T 1300 662 787 | F 1300 662 717
 22-24 Somerville Circuit, Emu Plains NSW 2750
 E sales@generalpumps.com.au www.generalpumps.com.au